

2MP Fixed Dome Network Camera

M285IPC-2MPF28 (40) (60)B-IR



Key Features

Optics

- Day/night functionality
- Optical glass window with higher light transmittance
- IR anti-reflection window to increase the infrared transmittance
- SmartIR, Up to 30 m (98 ft) IR distance
- 3D DNR (Digital Noise Reduction)

Compression

- H.265, H.264, MJPEG
- Embedded smart algorithm
- Triple streams
- 9:16 corridor mode

Network

- ONVIF Conformance

Structure

- Wide temperature range: -35°C to 60°C (-31°F to 140°F)
- Wide voltage range of $\pm 25\%$
- 4 KV surge protection designed for network interface
- IP67

Specifications

	M285IPC-2MPF28B-IR	M285IPC-2MPF40B-IR	M285IPC-2MPF60B-IR
Camera			
Sensor	1/2.7", 2megapixel, progressive scan, CMOS		
Lens	2.8mm@F1.8	4.0mm@F1.8	6.0mm@F1.8
Angle of view(H)	109.9°	80.8°	54.9°
Shutter	Auto/Manual, 1/6~1/100000 s		
Min. Illumination	Colour: 0.02 Lux (F1.8, AGC ON) 0 Lux with IR		
IR	30m (98ft) IR range		
Day/Night	IR-cut filter with auto switch (ICR)		
WDR	Digital		
AWB(Auto white balance)	Auto/manual		
Gain Control	Auto/manual		
Image Rotation	Supported		
Noise Reduction	2D/3D		
Video			
Max. Resolution	1920×1080		
Video Compression	H.265, H.264, MJPEG		
Frame Rate	1080P (1920×1080): Max. 30 fps; 720P (1280×720): Max. 30 fps; D1 (720×576): Max.30 fps		
Video Streaming	Triple		
9:16 Corridor Format	Supported		
Evaluative Metering	Supported		
OSD	Up to 8 OSDs		
Motion Detection	Up to 2 areas		
Privacy Mask	Up to 8 areas		
Smart			
Behavior Detection	Intrusion, crossing line, motion detection		
Intelligent Identification	Face detection, Defocus, Scene Change		
Statistical Analysis	People counting		
Network			
Protocols	IPv4, IGMP, ICMP, ARP, TCP, UDP, DHCP, PPPoE, RTP, RTSP, RTCP, DNS, DDNS, NTP, FTP, UPnP, HTTP, HTTPS, SMTP, 802.1x		
Compatible Integration	ONVIF,API		
Interface			
Network	10M/100M Base-TX Ethernet		
General			
Power	12 V DC, or PoE (IEEE802.3 af)		
	Power consumption: 3.5W (5.5W with IR on)		
Dimensions (Ø x H)	Ø126 x 94 mm (Ø5.0" x 3.7")		
Weight	0.33 kg (0.73lb)		
Working Environment	-35°C ~ +60°C (-31°F ~ 140°F), Humidity ≤ 90% RH(non-condensing)		
Ingress Protection	IP67		

Dimensions

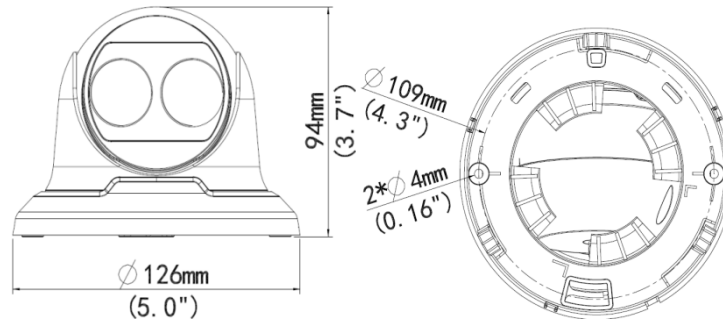

*Product specifications and availability are subject to change without notice.